



# 7/8" BORE ACCESSORIES



## CB-1795

Clevis Bracket  
Material: steel, bright zinc plated

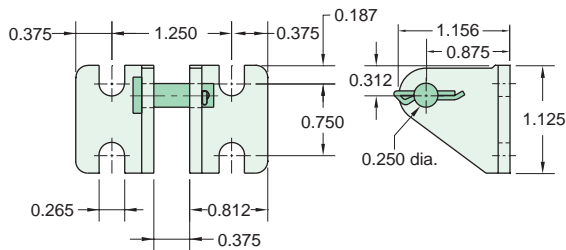

## RC-1281

Rod Clevis  
Material: steel, bright zinc plated

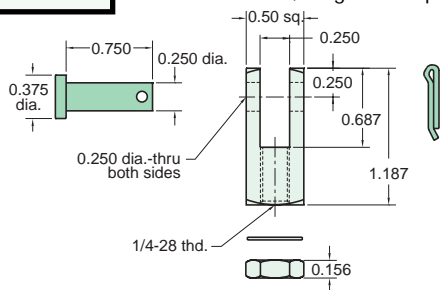

## FB-1791

Foot Bracket  
Material: steel, bright zinc plated

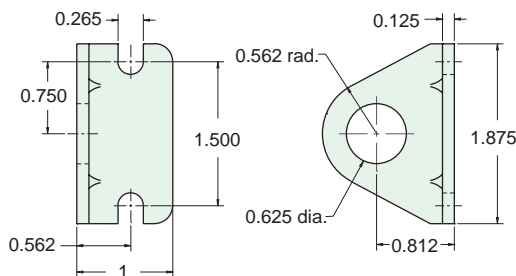

## MOUNTING NUTS

### Stud Nut

Part Number	Across Flats	Nut Thickness	Nut (Thread)
N10-18	15/16"	3/8"	5/8-18

### Rod Nut

Part Number	Across Flats	Nut Thickness	Nut (Thread)
N04-28A	7/16"	5/32"	1/4-28
N04-28B	3/8"	1/8"	1/4-28

## RE-1285

Rod End  
Material: steel, bright zinc plated body

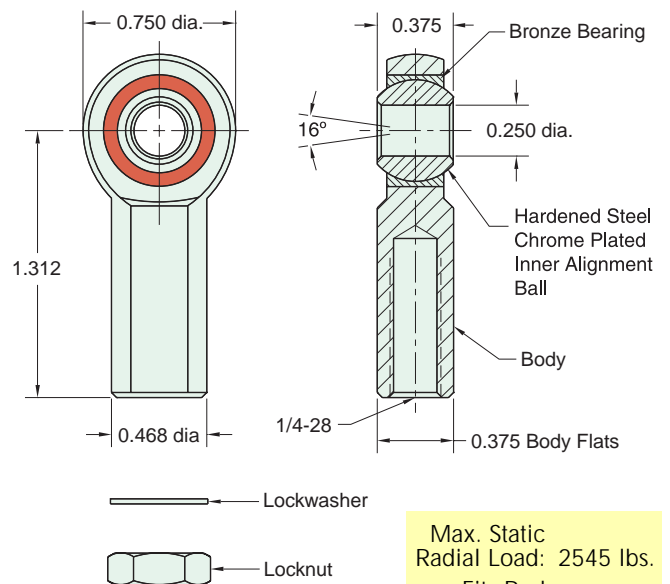

Max. Static Radial Load: 2545 lbs.  
Fits Rod Thread Size: 1/4-28